

NOE

Design Lievore Altherr Molina 2009

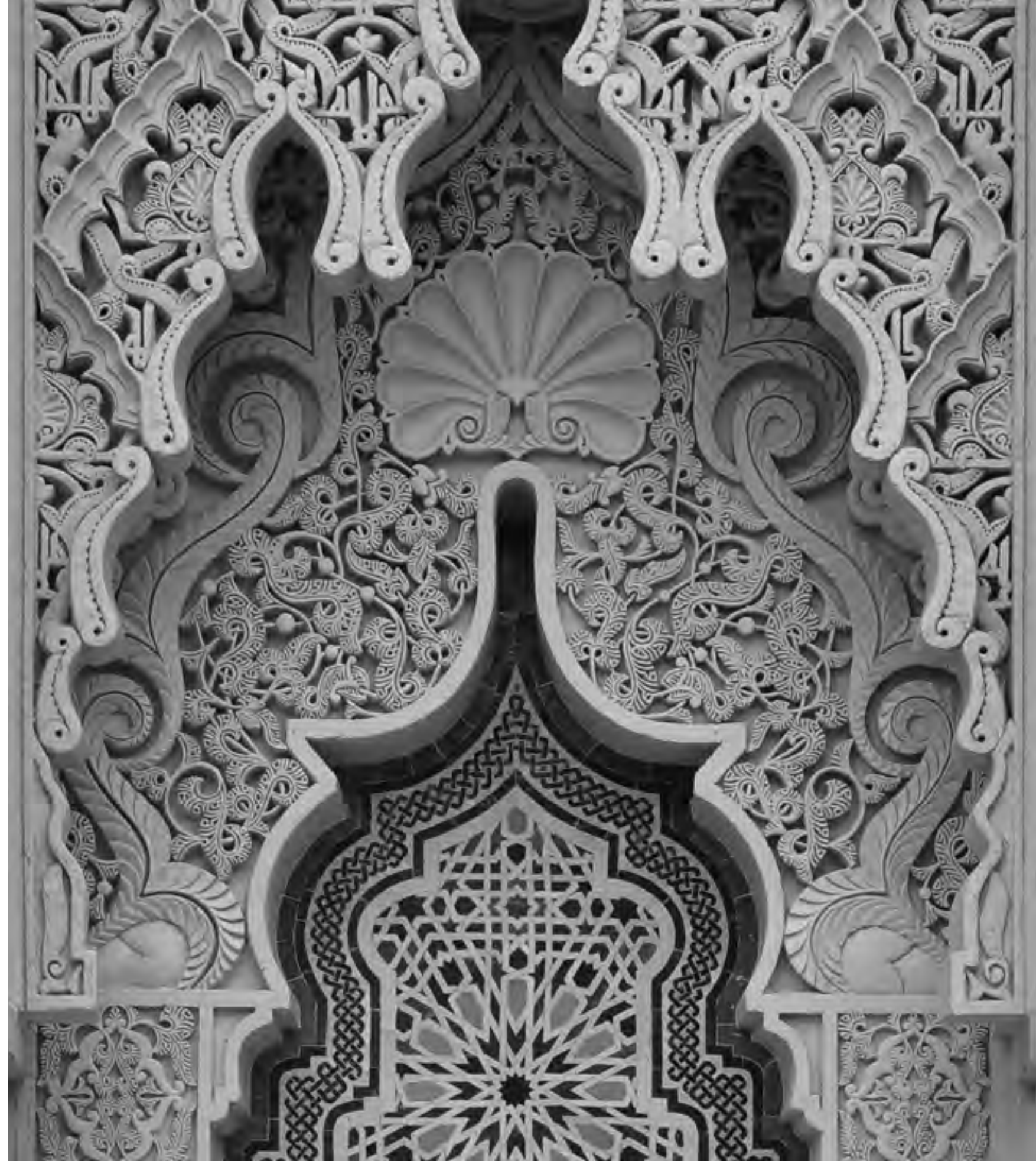



Noe Composizione descritta a pagina 337 Combination described at page 337 Zusammenstellung beschrieben auf Seite 337



Noe divano 250 sofa 250 Sofa 250 **Zoe** pouf Cubo in pelle Dakota pouf Cubo in leather Dakota Hocker Cubo in Leder Dakota





Noe Composizione descritta a pagina 337 Combination described at page 337 Zusammenstellung beschrieben auf Seite 337





Noe elementi 93 e pouf 93x93 elements 93 and pouf 93x93 Elemente 93 und Hocker 93x93



Noe Composizione descritta a pagina 337 Combination described at page 337 Zusammenstellung beschrieben auf Seite 337



Noe Composizione descritta a pagina 338 Combination described at page 338 Zusammenstellung beschrieben auf Seite 338

NOE PUNTO CAVALLO

Design Lievore Altherr Molina 2009

Noe Punto Cavallo 2 laterali 100 SX, DX 2 side pieces 100 SX, DX 2 Seitenteile 100 SX, DX
2 cuscini 46x46 2 cushions 46x46 2 Wurfkissen 46x46







Caratteristiche: La collezione Noe è un sistema che comprende divani così come numerosi elementi componibili, angoli, laterali, chaise longue e vari pouf, i quali, abbinati a piacere, offrono innumerevoli combinazioni. Si richiama alla serie Zoe presentata per la prima volta nel 2006 e diventata in pochi anni una icona del design. La struttura di Noe è realizzata in poliuretano autoportante: ciò consente una seduta tradizionale molto confortevole, senza perdere in brio e in leggerezza. A seconda del rivestimento scelto la fodera si realizza in tre diverse finiture: Al Vivo, Con Bordino o con impuntura "Punto Cavallo". La finitura "Punto Cavallo" si fornisce con supplemento di prezzo. Considerata la forma e le caratteristiche di Noe si sconsiglia l'utilizzo di tessuti troppo leggeri. Noe è attrezzabile con i tavolini Blog, che possono essere utilizzati come piani d'appoggio o, se corredati con i cuscini /bracciolo, come sostegni laterali. I cuscini/bracciolo sono disponibili rotondi o quadrati. E' disponibile un bracciolo appesantito, imbottito in lana, da sistemare sulla seduta per ottenere un comodo e stabile appoggio. Per un piano d'appoggio di maggiori dimensioni è possibile utilizzare il tavolino Argo. La collezione NOE è completamente e facilmente sfoderabile. Gli elementi vengono forniti di serie di un pratico sistema di aggancio. **Finiture disponibili:** - "Al Vivo": Si esegue esclusivamente con tessuti idonei (vedi listino prezzi) così come con tutti i tipi di pelle. In pelle, di serie, si realizza solo Al Vivo. - "Con Bordino": Con tutti gli altri tessuti la cucitura è di tipo tradizionale e con bordino dello stesso tessuto e colore. - "Punto Cavallo": Si tratta di un'impuntura decorativa disponibile in 11 colori (vedi pagina 270) da abbinare a piacere al tessuto scelto. Il tessuto è da selezionare fra quelli idonei. Questa finitura si fornisce con supplemento di prezzo. **Struttura-Imbottiture:** Pannello di base in multistrato, imbottitura realizzata in parte in poliuretano rigido e autoportante, che fa da struttura, e in parte in poliuretani di diverse densità, idonei ad assicurare un elevato comfort. La parte interna dello schienale e della seduta è rivestita da fibra poliestere tipo "BALL" contenuta in una fodera confezionata con tanti diversi scomparti ottenuti con numerose tramezze. Tutte le parti esterne sono invece rivestite da fibra poliestere in falda rivestita a sua volta da tela di cotone. L'imbottitura in fibra poliestere tipo "BALL" offre un comfort speciale, oltre che a donare un aspetto particolarmente vissuto proprio di questa fibra che va accettato in quanto voluto. Piedini in faggio laccati di colore nero.

Features: The NOE collection is a system that includes sofas as well as numerous sectional elements, corners, side elements, chaise lounge and various poufs, which, combined as desired, offer innumerable combinations. It recalls the Zoe series, first presented in 2006 and already in just a few years become an icon of design. The NOE framework is made of self-bearing polyurethane: this allows a very comfortable traditional seat without losing any of its appeal and lightness. According to upholstery cover is provided in three finishes: Visible Seams, Classical Stitching or with "Punto Cavallo" stitching. "Punto Cavallo" finish is available with up charge. Considering the shape and the characteristics of NOE we do not recommend fabrics that are too lightweight. NOE can be fitted with the BLOG tables, that can be used as work surfaces or, if equipped with cushions/armrest, as side supports. The cushions/armrest available are round or square. An heavy armrest with wool padding to be placed on the seat offers a stable and comfortable support. For a larger surface, it is possible to use the Argo table. Covers are completely and easily removable. The elements are supplied as standard with a practical hooking system. **Available Finishes:** - "Visible Seams": Can be provided with suitable fabrics (see price list) as well as with any kind of leather. In leather Zoe is provided as standard with Visible Seams only. - "Classical Stitching": With all other fabrics we provide classical stitching with piping in the same fabric and colour. - "Punto Cavallo": Decorative stitching available in 11 colours (see page 270) to be matched at pleasure with the fabric. Fabric has to be chosen among those specified as suitable. This finish is available with up charge. **Framework-Padding:** Plywood base-panel, padding made partly of rigid self-supporting polyurethane, forming the framework, and partly of polyurethane fibres in different densities, suitable to guarantee high comfort. The inside of the backrest and of the seat is covered by "BALL" type polyester fibre contained in a lining made of many different compartments obtained with numerous partitions. All the external parts are instead covered with flake polyester fibre covered, in its turn, by cotton cloth. The "BALL" type polyester padding provides special comfort, as well as giving a particularly aged appearance specific to this fibre that must be accepted as it is intentional. Black lacquered beech feet.

Eigenschaften: Die Kollektion NOE ist ein System aus Sofas und zahlreichen Elementen: Eckteile, Seitenteile, Chaiselongues und verschiedene Hocker, die nach eigenem Geschmack kombiniert werden können. NOE lehnt sich an das Modell Zoe an, das im Jahr 2006 vorgestellt wurde und schon jetzt zu einem Klassiker geworden ist. Die Struktur von NOE besteht aus Polyurethan; dies gewährleistet eine klassische, sehr bequeme und nicht zu stark federnde Sitzfläche. Je nach Wahl des Bezugs werden drei verschiedene Nähte genäht: Klaffnaht, Kedernaht oder die Ziernaht „Punto Cavallo“. Die Verarbeitung mit der Ziernaht „Punto Cavallo“ erfolgt gegen Aufpreis. Angesichts der charakteristischen Form von NOE wird von der Verwendung zu leichter Stoffe abgeraten. NOE kann mit den BLOG-Beistelltischen kombiniert werden. Die Beistelltische können dabei als Ablage verwendet werden oder sie dienen als Stütze der Armlehnenkissen. Die Kissen sind rund oder viereckig erhältlich. Ein extra schweres, mit Wolle gepolstertes, Armlehnenkissen, das auf die Sitzfläche gelegt werden kann, bietet eine bequeme und stabile Stütze. Wenn eine größere Ablagefläche gewünscht wird, kann der Beistelltisch ARGO eingesetzt werden. Die Kollektion NOE wird serienmäßig mit komplett abziehbaren Bezügen und mit Verbinder angeboten. **Ausführbare Nähte:** - „Klaffnaht“: wird ausnahmslos nur bei dazu geeigneten Stoffen (siehe Preisliste) und allen Lederarten verarbeitet. Die Standardausführung bei Lederbezügen ist immer mit Klaffnaht. - „Kedernaht“: Alle anderen Stoffe haben die traditionelle Naht mit Keder des gleichen Stoffes und der gleichen Farbe. - „Punto Cavallo“: Es handelt sich um einen Zierstich, der in 11 verschiedenen Farben (siehe Seite 270) realisierbar und mit dem gewählten, dafür geeigneten, Stoff kombinierbar ist. Diese Ziernaht ist gegen Aufpreis erhältlich. **Struktur und Polster:** Mehrschichtholz und Polyurethan, teilweise steif, selbsttragend und strukturbildend, teilweise in verschiedenen Dichten, sorgen für besten Komfort. Die Innenseite der Rückenlehne und die Oberseite der Sitzfläche sind mit der Polyesterfaser „BALL“ bezogen, die in einen, in einzelne Segmente geteilten Stoffbezug eingenäht ist. Die jeweiligen Außenseiten sind mit Polyesterflocken bedeckt, die ihrerseits mit Baumwollstoff bezogen sind. Die Polyesterpolsterung vom Typ „BALL“ bietet besonderen Komfort, ganz abgesehen von dem „gelebten“ Aussehen, das durch diese Faser entsteht und gewünscht ist. Die Füße sind aus schwarz lackierter Buche

SEZIONE SECTION SEKTION

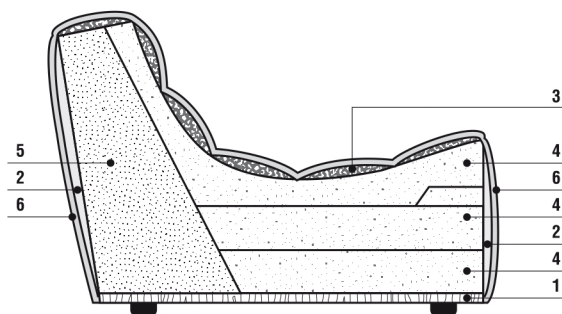

- 1: Pannello multistrato. Plywood base-panel. Mehrschichtholz.
- 2: Fibra Poliestere. Polyester Fibre. Polyesterfaser.
- 3: Fibra Poliestere Ball (insacchettata). Ball Polyester Fibre (pockets). Polyesterfaser "Ball" (beutelartig).
- 4: Poliuretano a densità differenziata. Differentiated density polyurethane. Polyurethan unterschiedlicher Dichte.
- 5: Poliuretano rigido autoportante. Self-supporting rigid polyurethane. Selbsttragendes steifes Polyurethan.
- 6: Fodera in tela. Fabric lining. Stoff-Futter.

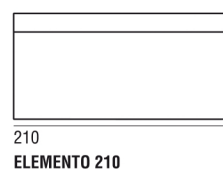
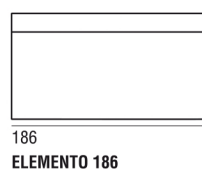
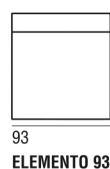
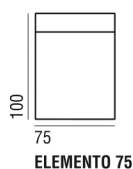
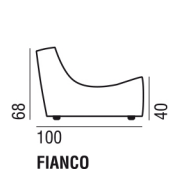

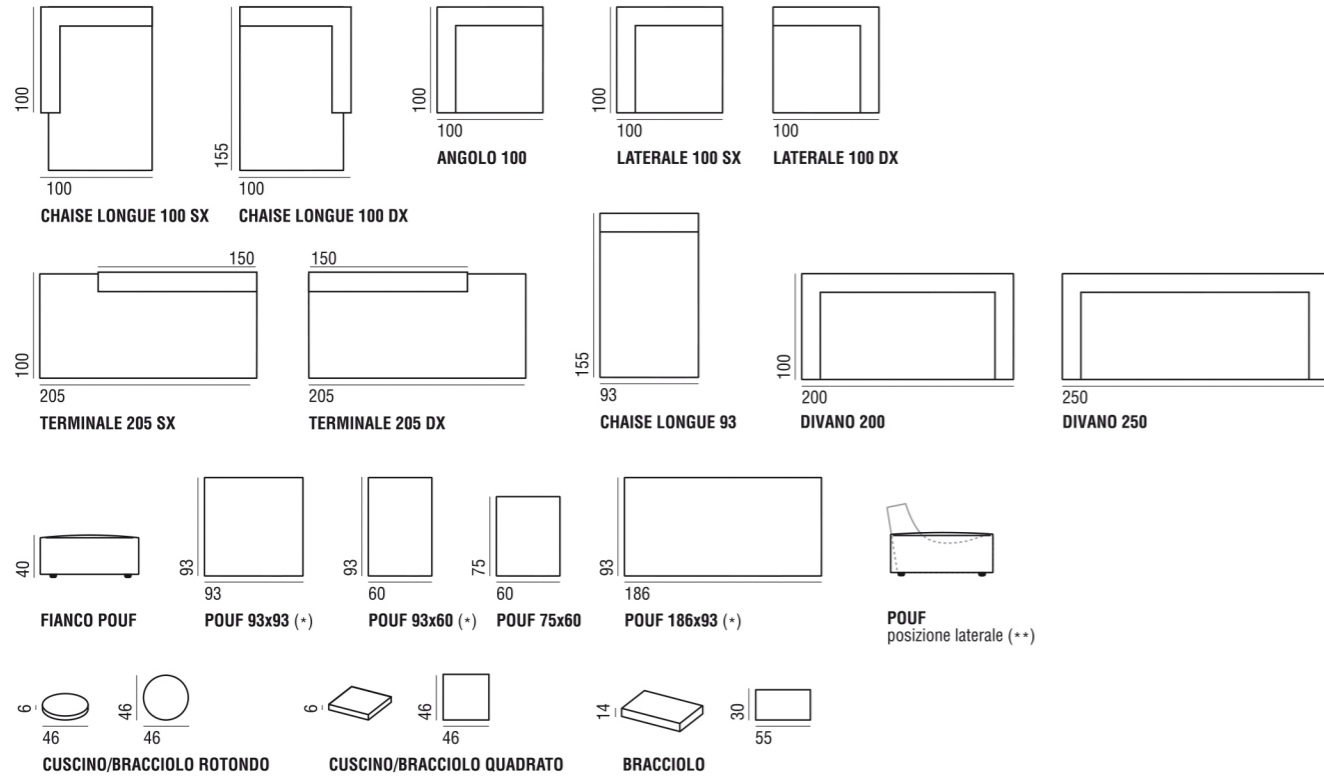

COMPLEMENTI

BLOG TAVOLINO ROTONDO design Lievore Altherr Molina (2006)



BLOG
 posizione fianco seduta
 placed on the side of the seat
 stehend neben der Sitzfläche

BLOG TAVOLINO RETTANGOLARE design Lievore Altherr Molina (2006)

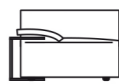
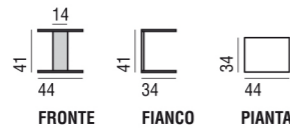

BLOG
 esempio "A" con cuscino-bracciolo
 example "A" with cushion/armrest
 beispiel "A" mit Kissen/Armlehne

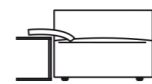

BLOG
 esempio "B" con cuscino-bracciolo
 example "B" with cushion/armrest
 beispiel "B" mit Kissen/Armlehne

BLOG TAVOLINO XL design Lievore Altherr Molina (2013)



TAVOLINO ARGO design Lievore Altherr Molina (2006)

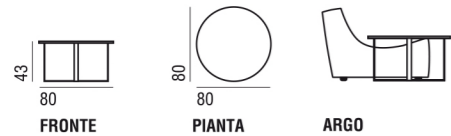

ARGO
 posizione fianco seduta
 placed on the side of the seat
 stehend neben der Sitzfläche

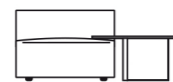

ARGO
 posizione fronte seduta
 seen from the front
 von vorn gesehen

TAVOLINO JIM design Lievore Altherr Molina (2010)

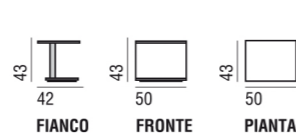

TAVOLINO JULES design Lievore Altherr Molina (2010)



(*) idoneo per essere posizionato anche lateralmente / ideal in a side position / Kann auch seitlich aufgestellt werden.
 (**) vista del pouf in posizione laterale / view of pouf in side position / Ansicht des Hockers in seitlicher Position.

Descrizione composizioni fotografate - Description of the photographed combinations - Beschreibung der gebildeten Zusammenstellungen

Foto pagine - photos at pages - Bilder auf Seiten: 84/85

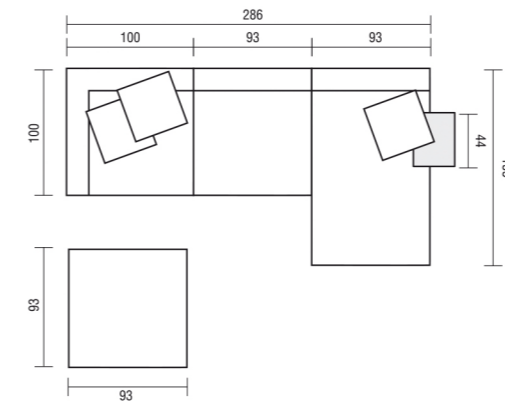

- | | | |
|------------------------------|--------------------------------|-----------------------------------|
| 1 laterale 100 SX | 1 side piece 100 SX | 1 Seitenteil 100 SX |
| 1 elemento 93 | 1 element 93 | 1 Element 93 |
| 1 chaise longue 93 | 1 chaise longue 93 | 1 Chaiselongue 93 |
| 1 pouf 93x93 | 1 pouf 93x93 | 1 Hocker 93x93 |
| 3 cuscini/bracciolo quadrati | 3 square cushions/armrest | 3 eckig Armlehnkissen |
| 1 tavolino Blog rettangolare | 1 Blog rectangular small table | 1 Blog rechteckiger Beistelltisch |

Foto pagina - photo at page - Bild auf Seite: 87

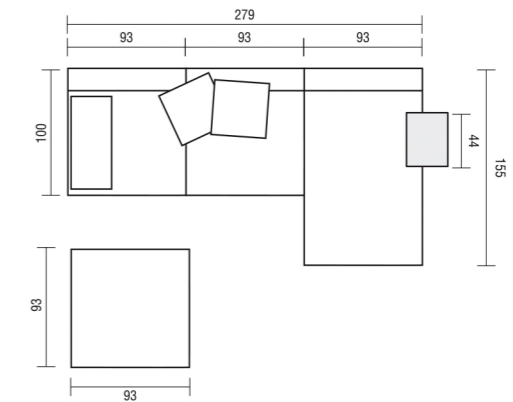

- | | | |
|------------------------------|--------------------------------|-----------------------------------|
| 2 elementi 93 | 2 elements 93 | 2 Elemente 93 |
| 1 chaise longue 93 | 1 chaise longue 93 | 1 Chaiselongue 93 |
| 2 cuscini/bracciolo quadrati | 2 square cushions/armrest | 2 eckig Armlehnkissen |
| 1 bracciolo | 1 armrest | 1 Armlehne |
| 1 tavolino Blog rettangolare | 1 Blog rectangular small table | 1 Blog rechteckiger Beistelltisch |
| 1 pouf 93x93 | 1 pouf 93x93 | 1 Hocker 93x93 |

Foto pagina - photo at page - Bild auf Seite: 93

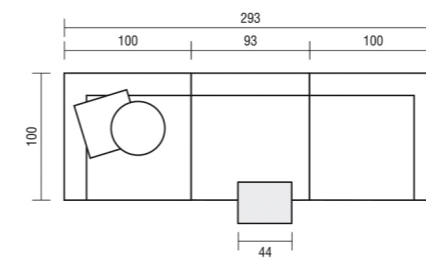

- | | | |
|------------------------------|--------------------------------|-----------------------------------|
| 1 laterale 100 SX | 1 side piece 100 SX | 1 Seitenteil 100 SX |
| 1 laterale 100 DX | 1 side piece 100 DX | 1 Seitenteil 100 DX |
| 1 elemento 93 | 1 element 93 | 1 Element 93 |
| 1 cuscino/bracciolo quadrato | 1 square cushion/armrest | 1 eckig Armlehnkissen |
| 1 cuscino/bracciolo rotondo | 1 round cushion/armrest | 1 rund Armlehnkissen |
| 1 tavolino Blog rettangolare | 1 Blog rectangular small table | 1 Blog rechteckiger Beistelltisch |

Foto pagina - photo at page - Bild auf Seite: 96

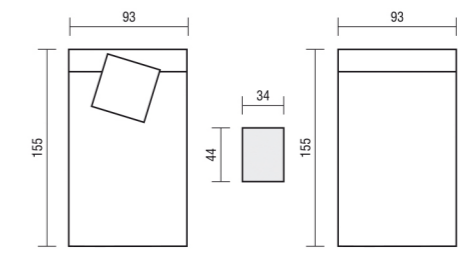

- | | | |
|------------------------------|--------------------------------|-----------------------------------|
| 2 chaise longue 93 | 2 chaise longue 93 | 2 Chaiselongue 93 |
| 1 cuscino/bracciolo quadrato | 1 square cushion/armrest | 1 eckig Armlehnkissen |
| 1 tavolino Blog rettangolare | 1 Blog rectangular small table | 1 Blog rechteckiger Beistelltisch |

Foto pagina - photo at page - Bild auf Seite: 97

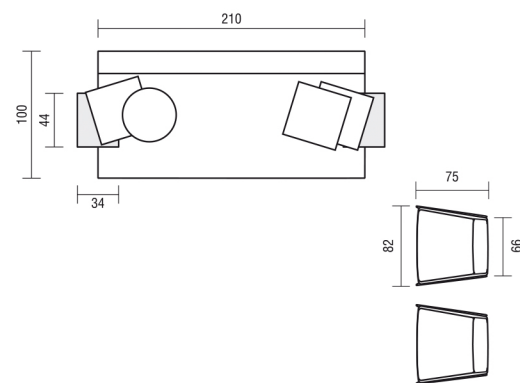

- | | | |
|------------------------------|---------------------------------|-----------------------------------|
| 1 elemento 210 | 1 element 210 | 1 Element 210 |
| 3 cuscini/bracciolo quadrati | 3 square cushions/armrest | 3 eckig Armlehnhkissen |
| 1 cuscino/bracciolo rotondo | 1 round cushion/armrest | 1 rund Armlehnhkissen |
| 2 tavolini Blog rettangolare | 2 Blog rectangular small tables | 2 Blog rechteckiger Beistelltisch |
| 2 Kelly poltrone | 2 Kelly armchairs | 2 Kelly Sessel |

Foto pagine - photos at pages - Bilder auf Seiten: 100/101

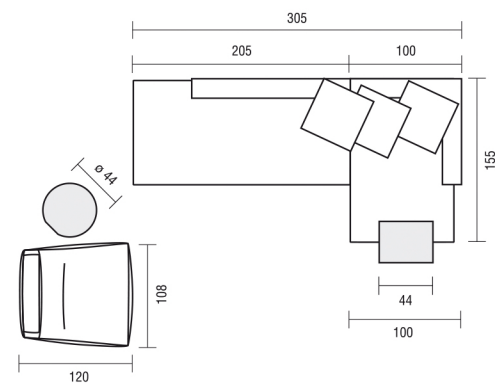

- | | | |
|------------------------------|--------------------------------|-----------------------------------|
| 1 terminale 205 SX | 1 end piece 205 SX | 1 Endstück 205 SX |
| 1 chaise longue 100 DX | 1 chaise longue 100 DX | 1 Chaiselongue 100 DX |
| 1 tavolino Blog rettangolare | 1 Blog rectangular small table | 1 Blog rechteckiger Beistelltisch |
| 1 tavolino Blog rotondo | 1 Blog round small table | 1 Blog runder Beistelltisch |
| 1 poltrona Zoe | 1 armchair Zoe | 1 Sessel Zoe |



Verzelli
Strada Langhirano, 215
43124 Parma (Italy)
ph +39 0521 648111 / 648424
fx +39 0521 648626
www.verzelli.it
verzelli@verzelli.it

Artwork:

Art direction
Corrado Mantovani
Antonella Frezza

Graphic design
Europa.it

Interior styling
Antonella Frezza
Ravaolisenzistudio

Credits:

Photographers
Alberto Tagliabue
Verzelli Photo Archive

Thanks to:

Avec Arcade
Belux
Gandia Blasco
JNet
Luceplan
Muji Italia
Nava Design
Nic Design
Parentesi Quadra
Society
Solzi Luce
William Xerra

Antonino Sciortino
Artek
EO collection
Foscarini
Fraulux
Kinnasand
Penta
Rapsel
Somma